

Customer Information Sheet

DRAWING No.: M300-0010045

IF IN DOUBT - ASK

©

NOT TO SCALE

THIRD ANGLE PROJECTION

ALL DIMENSIONS IN mm

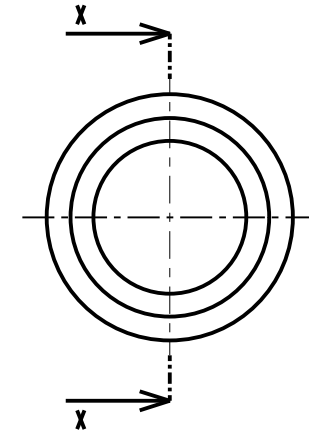
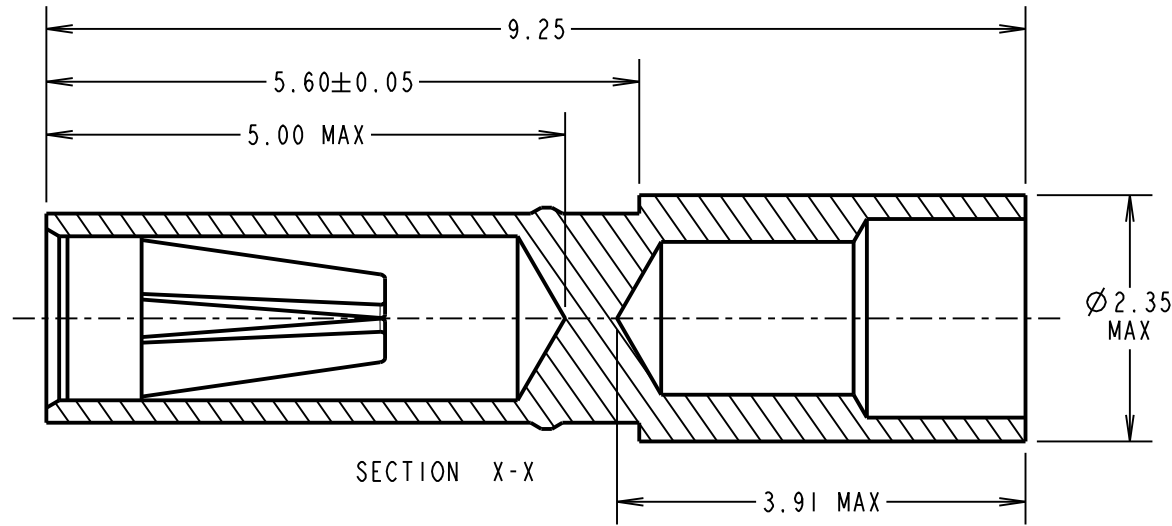

SPECIFICATION:

MATERIAL:

CONTACT SHELL = BRASS
CONTACT CLIP = BERYLLIUM COPPER

FINISH:

0.28µ GOLD SHELL, 0.15µ GOLD CLIP

MECHANICAL:

INSERTION FORCE = 9N MAX
WITHDRAWAL FORCE = IN MIN
DURABILITY = 1000 OPERATIONS

ENVIRONMENTAL:

OPERATING TEMPERATURE = -65°C TO +175°C

PACKING:

BULK

FOR COMPLETE CONNECTOR SPECIFICATION, SEE COMPONENT SPECIFICATION C048XX (LATEST ISSUE)

NOTES:

- SUITABLE FOR WIRE GAUGE 18 & 20 AWG. MAXIMUM INSULATION DIAMETER Ø1.80mm, BS3G210 TYPE A WIRE RECOMMENDED. STRIP WIRE BY 2.00mm FOR CRIMPING.
- RECOMMENDED CRIMP TOOL = M22520/2-01, POSITIONER = Z80-058.
- FOR INSTRUCTIONS ON HAND CRIMP TOOL M22520/2-01, SEE INSTRUCTION SHEET IS-01.
- RECOMMENDED MATING PIN SIZE = Ø1.05-0.90mm.

MGP	3	19.09.14	12587
NAME	ISS.	DATE	C/NOTE
APPROVED: MGP			
CHECKED: SB			
DRAWN: MARK G PLESTED			
CUSTOMER REF.:			
ASSEMBLY DRG:			

HARWIN

www.harwin.com
technical@harwin.com

THIS DRAWING AND ANY INFORMATION OR DESCRIPTIVE MATTER SET OUT HEREON ARE CONFIDENTIAL AND COPYRIGHT PROPERTY OF THE HARWIN GROUP AND MUST NOT BE DISCLOSED, LOANED, COPIED OR USED FOR MANUFACTURING, TENDERING OR FOR ANY OTHER PURPOSE WITHOUT THEIR WRITTEN PERMISSION.

TOLERANCES

X. = ±1mm
X.X = ±0.50mm
X.XX = ±0.10mm
X.XXX = ±0.01mm
ANGLES = ±5°
UNLESS STATED

MATERIAL:

SEE ABOVE

FINISH: SEE ABOVE

S/AREA: mm²

TITLE:

1mm CRIMP LARGE BORE SOCKET ASSEMBLY

DRAWING NUMBER:

M300-0010045

SHT
2 OF 2